

SUMMERPLANS, LLC

PHONE: (337) 207-3907

EMAIL: ked@summerplansllc.com

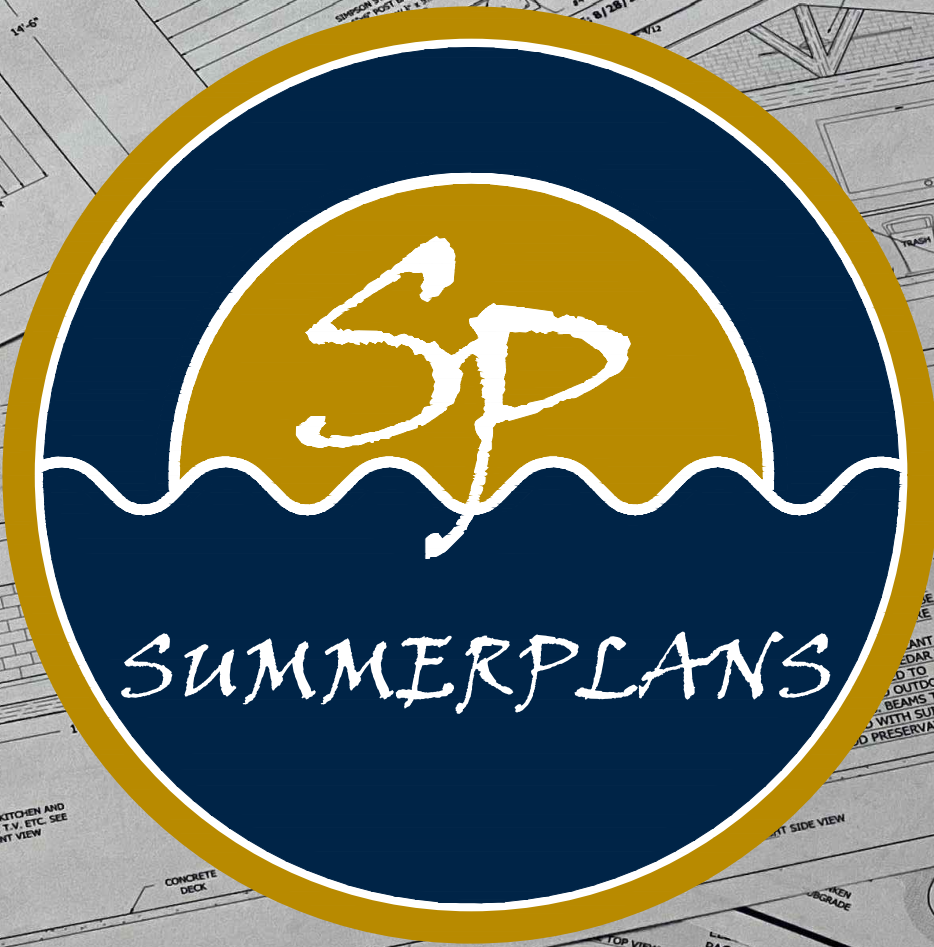

**SAMPLE PLAN:
PERMIT PLANS FOR
POOL & DECK**

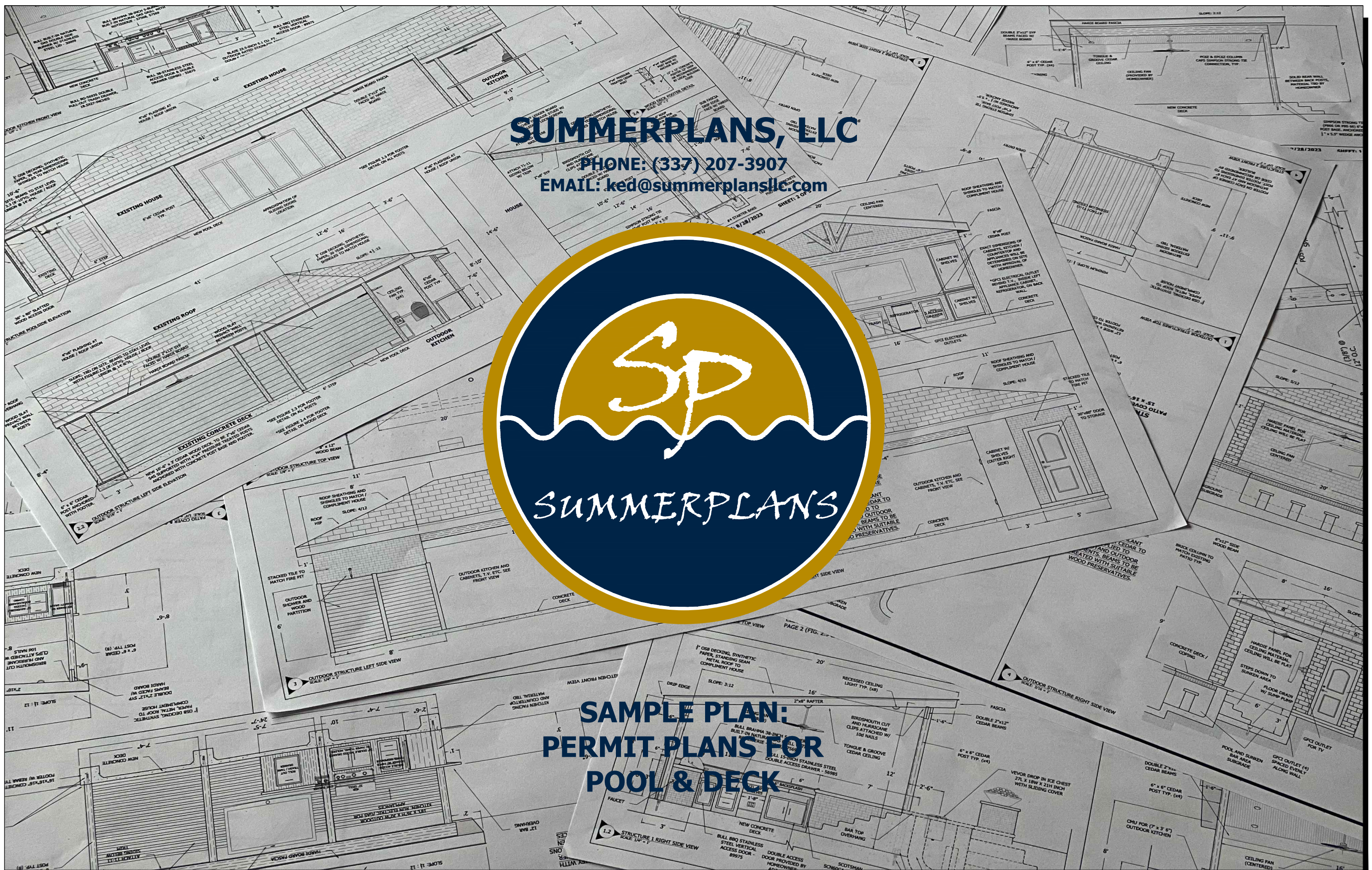

COMPANY LOGO
 COMPANY NAME, LLC
 STREET ADDRESS
 CITY, STATE, ZIP CODE
 PHONE #

PROJECT NAME POOL PERMIT/HOA PLAN

STREET ADDRESS, CITY, STATE ZIP CODE

SUBDIVISION: _____ LOT#: _____ BLOCK _____ JURISDICTION: _____

CUSTOMER INFO

NAME: _____ CUSTOMER NAME
 ADDRESS: _____ CUSTOMER ADDRESS
 EMAIL: _____ CUSTOMER EMAIL
 PHONE: _____ (XXX) XXX-XXXX
 DESIGNER: _____ DESIGNER NAME
 DRAFTSMAN: _____ SUMMERPLANS

POOL SPECS

PERIMETER: 102 FT RETURNS: 4
 AREA: 510 SF SKIMMERS: 2
 DIMENSIONS: 30'-0" x 20'-0" AUTOFILL: YES
 DEPTH: 3'-6" to 5'-0" BUBBLERS: (2) LED
 VOLUME: 16,256 GAL. UMB. SLEEVES: 2
 ELEVATION: -12" LIGHTS: (3) 24W COLOR LEDS
 DRAINS: 2 SHEERS: (1) 24"
 MATERIAL: GUNITE DECK JETS: 3
 COPING: IVORY TRAVERTINE 5CM
 INTERIOR FINISH: STANDARD WET EDGE SIGNATURE MATRIX
 WATERLINE TILE: STANDARD TILE
 NOTES:

SPA SPECS

PERIMETER: 28 FT DRAINS: 2
 AREA: 49 SF MATERIAL: GUNITE
 DIMENSIONS: 7'-0" x 7'-0" JETS: 6
 DEPTH: 3'-6" LIGHTS: (1) 6W COLOR LED
 VOLUME: 730 GAL. SPILLOVER: 14'-0" TILED
 HEIGHT: +12" BLOWER: YES
 COPING: IVORY TRAVERTINE 5CM
 INTERIOR FINISH: STANDARD WET EDGE SIGNATURE MATRIX
 WATERLINE TILE: STANDARD TILE
 RAISED FACE: SPLITFACE TRAVERTINE
 NOTES:

EQUIPMENT SPECS

CIRCULATION PUMP: JANDY ePUMP 2.7HP VS
 ADD'L PUMP(S): JANDY ePUMP 2.7HP VS
 FILTER: JANDY CV 460 CARTRIDGE
 HEATER: JANDY JX1 400K BTU NG
 SANITATION: NATURE2FUSION CHLORINATOR
 ADD'L SANITATION: DEL AOP S WALL MOUNT (25K GAL.)
 AUTOMATION: iAquaLink IQ904PS
 POOL CLEANER: POLARIS ALPHA IQ+
 HEAT PUMP / CHILLER: N/A
 ACTUATORS: N/A PLUMBING RUN: 45 LF
 ELEC. RUN: 10 LF STRAPPED GAS RUN: 10 LF STRAPPED
 NOTES:

DECK SPECS

PERIMETER: N/A AREA: 683 SF
 SURFACE MATERIAL: SPRAY DECK
 COPING AREA / MATERIAL: N/A
 RAISED BEAMS (RBB): (6'+12"), (8'+18")
 (2) (2'x2') SQUARE PILLARS @ (+18")
 RBB FACE/BACK: SPLITFACE TRAVERTINE / BROWNCOAT
 NOTES:

ADD'L FEATURES / NOTES

INCLUDES STEP/BENCH/LEDGE TRIM TILE
 INCLUDES BAR TOP OVERHANG W/ (4) BAR STOOLS
 INCLUDES SUNKEN DECK W/ RETAINING WALLS
 INCLUDES (1) GFCI PROTECTED ELECTRICAL OUTLET
 INCLUDES (2) FIRE/WATER BOWLS
 INCLUDES PLANTER (14'-0" x 2'-0") @ (+18")

REVISION	DATE
INITIAL PLAN	XX-XX-XX
1	
2	
3	

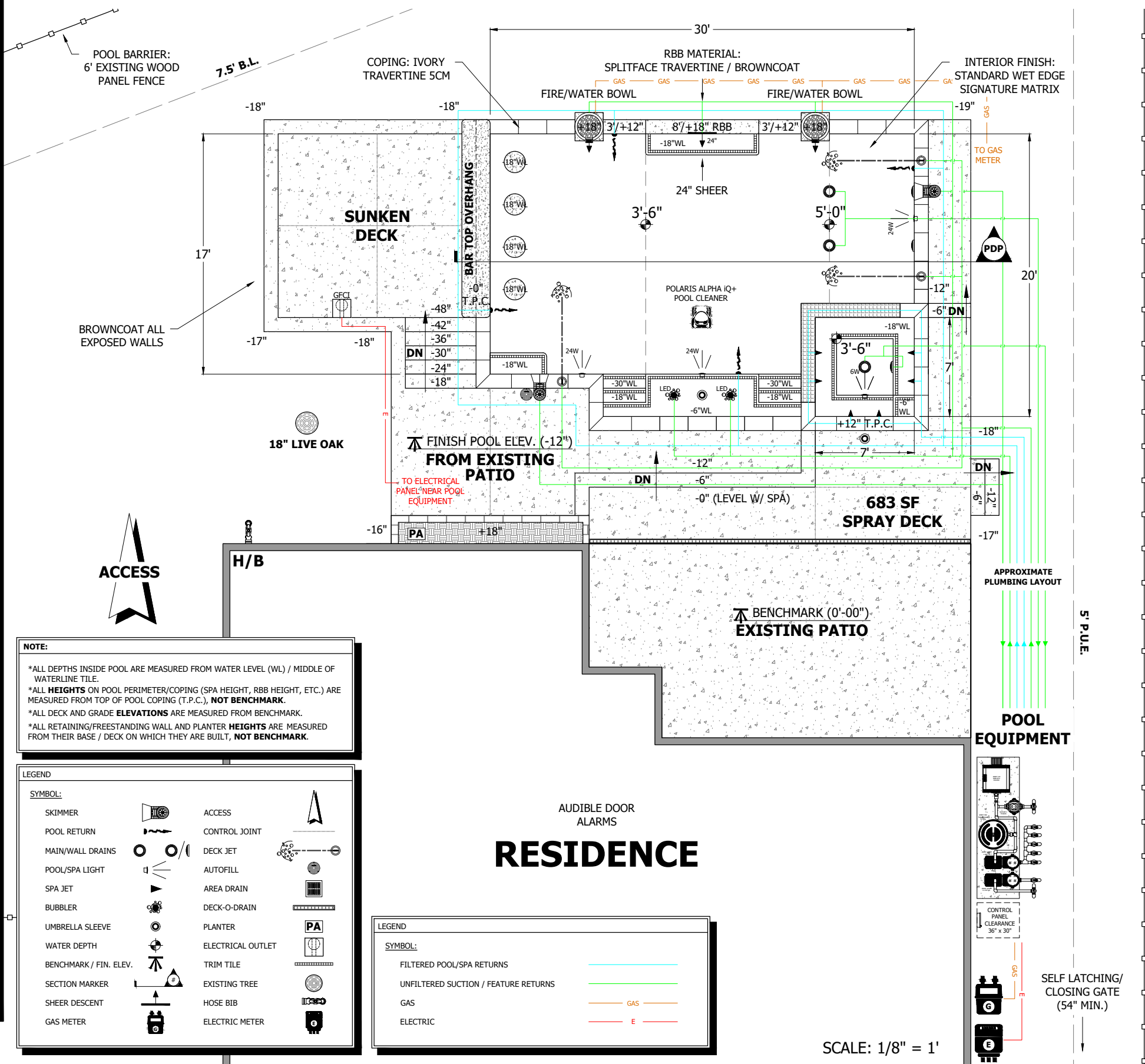

NOTE:

*ALL DEPTHS INSIDE POOL ARE MEASURED FROM WATER LEVEL (WL) / MIDDLE OF WATERLINE TILE.
 *ALL HEIGHTS ON POOL PERIMETER/COPING (SPA HEIGHT, RBB HEIGHT, ETC.) ARE MEASURED FROM TOP OF POOL COPING (T.P.C.), NOT BENCHMARK.
 *ALL DECK AND GRADE ELEVATIONS ARE MEASURED FROM BENCHMARK.
 *ALL RETAINING/FREESTANDING WALL AND PLANTER HEIGHTS ARE MEASURED FROM THEIR BASE / DECK ON WHICH THEY ARE BUILT, NOT BENCHMARK.

LEGEND

SYMBOL:			
SKIMMER		ACCESS	
POOL RETURN		CONTROL JOINT	
MAIN/WALL DRAINS		DECK JET	
POOL/SPA LIGHT		AUTOFILL	
SPA JET		AREA DRAIN	
BUBBLER		DECK-O-DRAIN	
UMBRELLA SLEEVE		PLANTER	
WATER DEPTH		ELECTRICAL OUTLET	
BENCHMARK / FIN. ELEV.		TRIM TILE	
SECTION MARKER		EXISTING TREE	
SHEER DESCENT		HOSE BIB	
GAS METER		ELECTRIC METER	

LEGEND

SYMBOL:	
FILTERED POOL/SPA RETURNS	
UNFILTERED SUCTION / FEATURE RETURNS	
GAS	
ELECTRIC	

SCALE: 1/8" = 1'

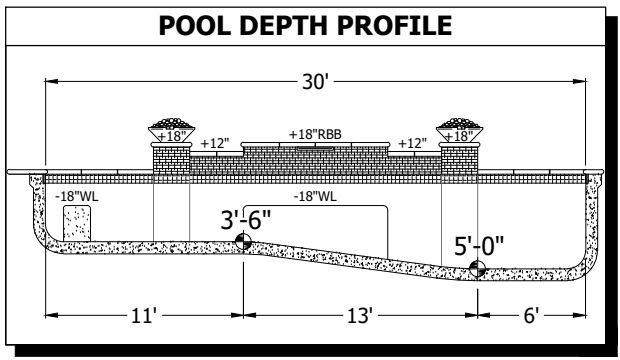
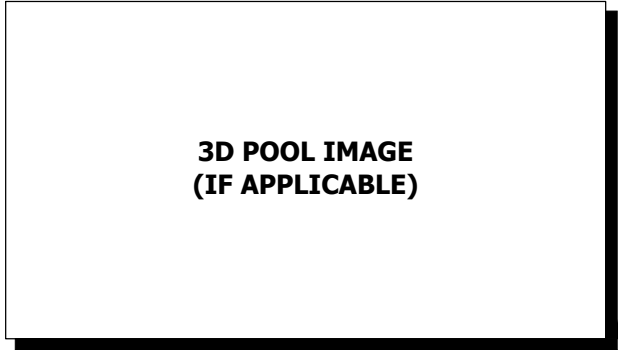

- PROJECT/CONSTRUCTION NOTES:**
- ELEVATIONS TO BE SET AT TIME OF EXCAVATION.
 - NO CONSTRUCTION WILL BE IN THE P.U.E.
 - ANY NECESSARY REMOVAL OF PANELS FOR ACCESS WILL BE REINSTALLED AFTER CONSTRUCTION.
 - BONDING HALO REQUIRED, WITH A MINIMUM OF 7 POINTS OF CONTACT.
 - ALL ELECTRICAL BONDING WILL BE IN ACCORDANCE WITH THE 2020 NATIONAL ELECTRICAL CODE.
 - ELECTRIC TO LIGHTS TO BE RUN THROUGH PLASTIC CONDUIT BURIED 12" MIN.
 - POOL BONDING WIRE TYPE WILL BE UNINTERRUPTED, SOLID COPPER WIRE SIZE #8.
 - LIGHTING WILL NOT ILLUMINATE ONTO ADJOINING NEIGHBORHOOD PROPERTIES.
 - SUPPLY SAND OR SOFT BACKFILL MATERIAL FOR PLUMBING TRENCH PRIOR TO POOL SHELL INSPECTION. NO ROCKS OR DEBRIS PERMITTED BY 2015 IPC SECTION.
 - TREES 19" OR GREATER WILL BE PROTECTED.
 - SOIL APPROVED UNDER AND AROUND POOL.
 - DRAINAGE WILL NOT ADVERSELY IMPACT ADJOINING LOTS. DRAINAGE EXITING THE LOT ONTO AN ADJUTTING PROPERTY WILL BE DIRECTED TO A COMMON PROPERTY PIN.
 - ALL MATERIAL WILL MATCH/COMPLIMENT HOUSE (IF REQUIRED).
 - POOL WALLS ABOVE GRADE WILL BE VENEERED WITH ROCK, BRICK, OR STUCCO AND MATCH HOUSE (IF REQUIRED).
 - EQUIPMENT TO BE SCREENED ON ALL SIDES. SCREENING WILL BE STUCCO OR ROCK TO MATCH/COMPLIMENT EXISTING HOUSE. GATE WILL BE PROVIDED ACROSS OPENING FOR MAINTENANCE ACCESS (IF OWNERS MUST PASS AND COMPLY WITH POOL BARRIER CODES).
 - EQUIPMENT AND COVERS FOR OUTDOOR HEATED POOLS/SPAS WILL COMPLY WITH 2021 IECC REQUIREMENTS.
 - POOL CIRCULATION TURNOVER RATE IS 6 HRS.
 - SAFETY FEATURES WILL COMPLY WITH SECTION 811 OF 2021 ISPCS.
 - ALL DOORS LEADING TO POOL WILL HAVE CODE COMPLIANT AUDIBLE ALARMS.
 - SELF CLOSING/SELF LATCHING GATE (54") PER CODE, APPENDIX "G".
 - EXISTING POOL BARRIER COMPLIES WITH SECTION 305 OF 2021 ISPCS.
 - OWNERS MUST PASS AND COMPLY WITH POOL BARRIER CODES:
 - POOL BARRIER INSPECTION PRIOR TO FILLING POOL.
 - LAYOUT INSPECTION PRIOR TO FILLING THE POOL.
 - GATE TO OPEN AWAY FROM POOL.
 - LATCH TO BE 54" MIN. FROM GROUND.
 - OPENINGS ON ANY BARRIER OR GATE MUST BE LESS THAN 3.99".
 - 36" CLEARANCE REQUIRED IN FRONT OF THE ELECTRICAL PANEL.
 - FOR MORE COMPLIANCE INFO, SEE INDIVIDUAL CITY ORDINANCES.

PROJECT NAME POOL DETAILS

STREET ADDRESS, CITY, STATE ZIP CODE

SUBDIVISION: _____ LOT#: _____ BLOCK _____ JURISDICTION: _____

COMPANY LOGO

COMPANY NAME, LLC
STREET ADDRESS
CITY, STATE, ZIP CODE
PHONE #

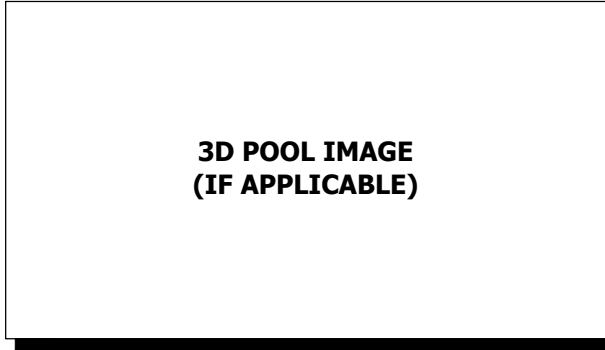

CUSTOMER INFO

NAME: _____ CUSTOMER NAME
ADDRESS: _____ CUSTOMER ADDRESS
EMAIL: _____ CUSTOMER EMAIL
PHONE: _____ (XXX) XXX-XXXX
DESIGNER: _____ DESIGNER NAME
DRAFTSMAN: _____ SUMMERPLANS

POOL SPECS

PERIMETER: 102 FT RETURNS: 4
AREA: 510 SF SKIMMERS: 2
DIMENSIONS: 30'-0" x 20'-0" AUTOFILL: YES
DEPTH: 3'-6" to 5'-0" BUBBLERS: (2) LED
VOLUME: 16,256 GAL. UMB. SLEEVES: 2
ELEVATION: -12" LIGHTS: (3) 24W COLOR LEDS
DRAINS: 2 SHEERS: (1) 24"
MATERIAL: GUNITE DECK JETS: 3
COPING: IVORY TRAVERTINE 5CM
INTERIOR FINISH: STANDARD WET EDGE SIGNATURE MATRIX
WATERLINE TILE: STANDARD TILE
NOTES:

SPA SPECS

PERIMETER: 28 FT DRAINS: 2
AREA: 49 SF MATERIAL: GUNITE
DIMENSIONS: 7'-0" x 7'-0" JETS: 6
DEPTH: 3'-6" LIGHTS: (1) 6W COLOR LED
VOLUME: 730 GAL. SPILLOVER: 14'-0" TILED
HEIGHT: +12" BLOWER: YES
COPING: IVORY TRAVERTINE 5CM
INTERIOR FINISH: STANDARD WET EDGE SIGNATURE MATRIX
WATERLINE TILE: STANDARD TILE
RAISED FACE: SPLITFACE TRAVERTINE
NOTES:

EQUIPMENT SPECS

CIRCULATION PUMP: JANDY ePUMP 2.7HP VS
ADD'L PUMP(S): JANDY ePUMP 2.7HP VS
FILTER: JANDY CV 460 CARTRIDGE
HEATER: JANDY JXI 400K BTU NG
SANITATION: NATURE2FUSION CHLORINATOR
ADD'L SANITATION: DEL AOP S WALL MOUNT (25K GAL.)
AUTOMATION: iAquaLink IQ904PS
POOL CLEANER: POLARIS ALPHA IQ+
HEAT PUMP / CHILLER: N/A
ACTUATORS: N/A PLUMBING RUN: 45 LF
ELEC. RUN: 10 LF STRAPPED GAS RUN: 10 LF STRAPPED
NOTES:

DECK SPECS

PERIMETER: N/A AREA: 683 SF
SURFACE MATERIAL: SPRAY DECK
COPING AREA / MATERIAL: N/A
RAISED BEAMS (RBB): (6'/+12"), (8'/+18")
(2) (2'x2') SQUARE PILLARS @ (+18")
RBB FACE/BACK: SPLITFACE TRAVERTINE / BROWNCOAT
NOTES:

ADD'L FEATURES / NOTES

INCLUDES STEP/BENCH/LEDGE TRIM TILE
INCLUDES BAR TOP OVERHANG W/ (4) BAR STOOLS
INCLUDES SUNKEN DECK W/ RETAINING WALLS
INCLUDES (1) GFCI PROTECTED ELECTRICAL OUTLET
INCLUDES (2) FIRE/WATER BOWLS
INCLUDES PLANTER (14'-0" x 2'-0") @ (+18")

POOL BARRIER / FENCE

SCALE: N/A

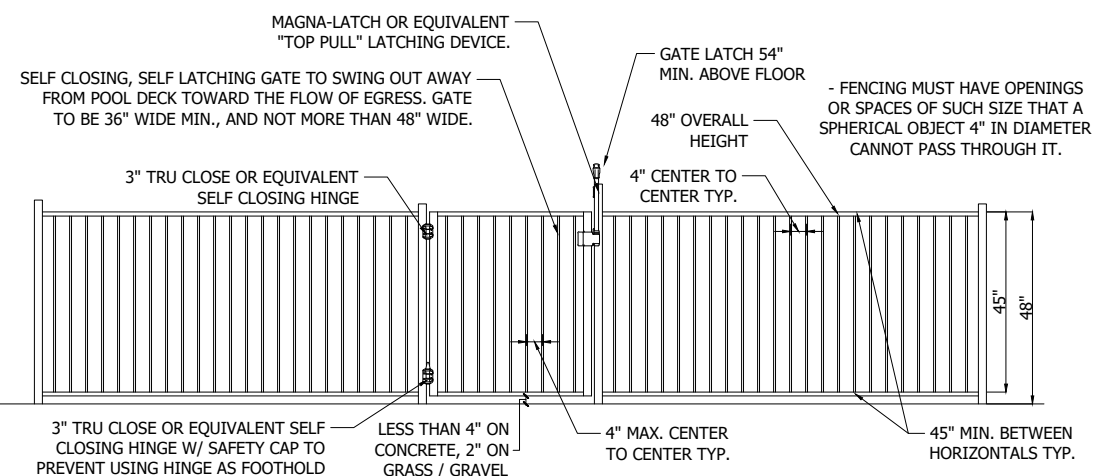

POOL BARRIER / FENCE

SCALE: N/A

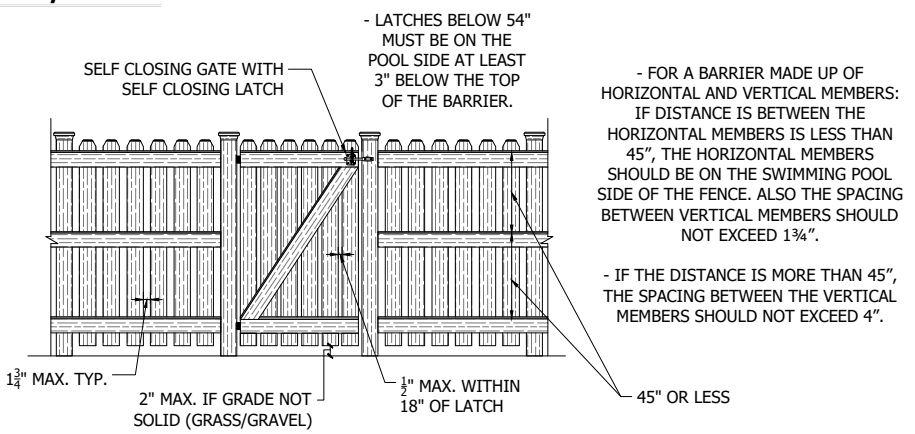

POOL BONDING DETAIL

SCALE: N/A

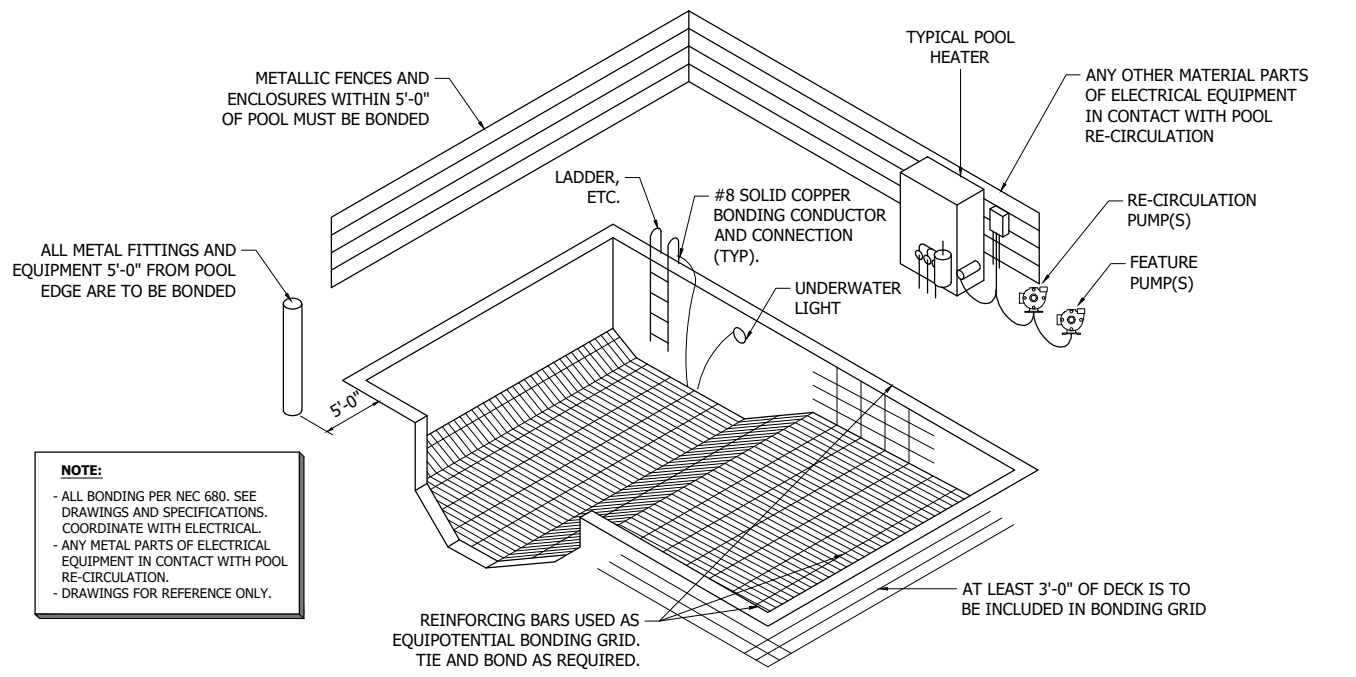

NOTE:
- ALL BONDING PER NEC 680. SEE DRAWINGS AND SPECIFICATIONS. COORDINATE WITH ELECTRICAL.
- ANY METAL PARTS OF ELECTRICAL EQUIPMENT IN CONTACT WITH POOL RE-CIRCULATION.
- DRAWINGS FOR REFERENCE ONLY.

POOL BOND BEAM / DECK DETAIL

SCALE: 1/2" = 1'

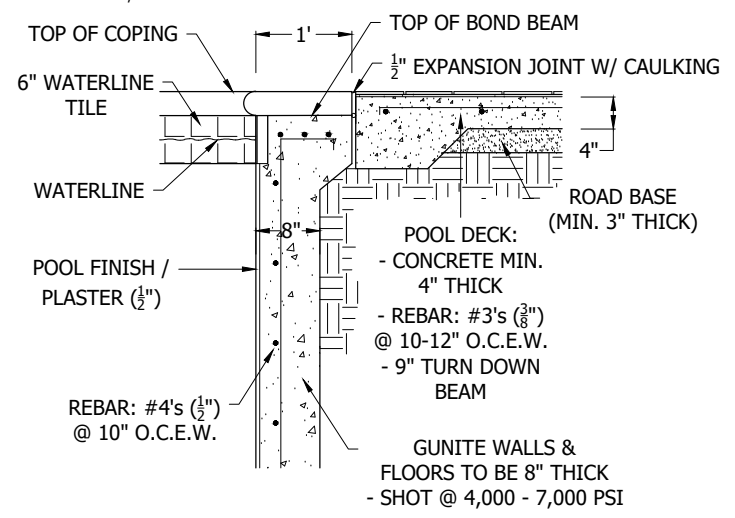

TANNING LEDGE & STEPS DETAIL

SCALE: 1/2" = 1'

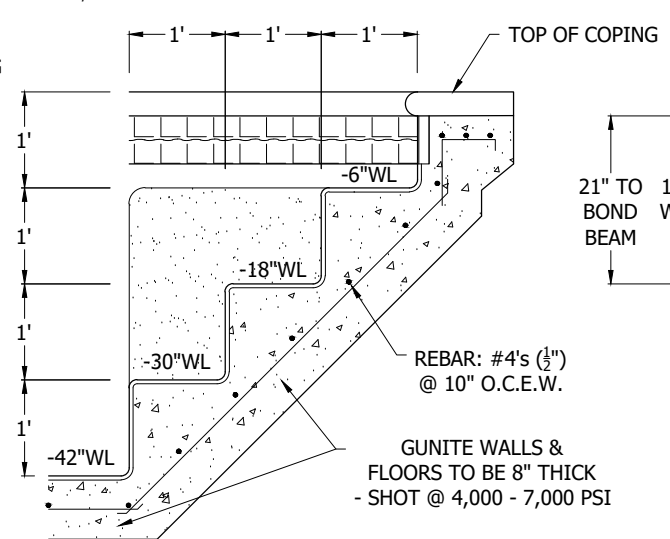

POOL BENCH DETAIL

SCALE: 1/2" = 1'

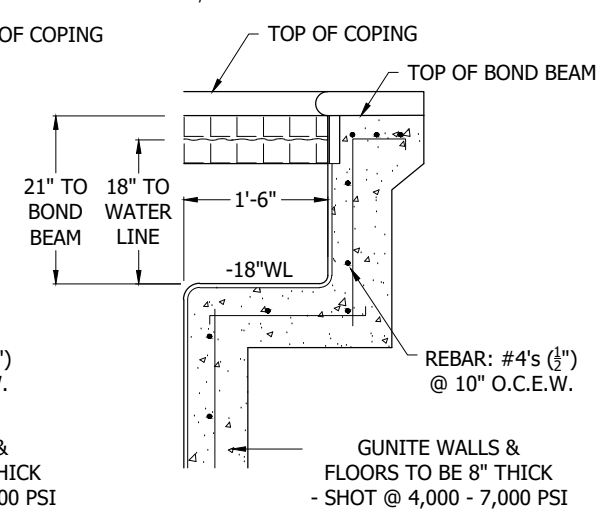

RAISED SPA/WALL DETAIL

SCALE: 1/2" = 1'

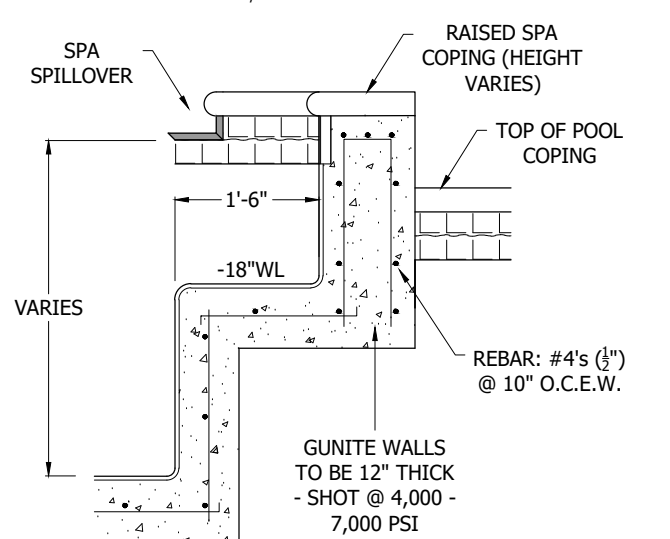

REVISION	DATE
INITIAL PLAN	XX-XX-XX
1	
2	
3	

COMPANY
LOGO

COMPANY NAME, LLC
STREET ADDRESS
CITY, STATE, ZIP CODE
PHONE #

PROJECT NAME 3D POOL IMAGES

STREET ADDRESS, CITY, STATE ZIP CODE

SUBDIVISION: _____ LOT#: _____ BLOCK _____ JURISDICTION: _____

CUSTOMER INFO

NAME: _____ CUSTOMER NAME
ADDRESS: _____ CUSTOMER ADDRESS
EMAIL: _____ CUSTOMER EMAIL
PHONE: _____ (XXX) XXX-XXXX
DESIGNER: _____ DESIGNER NAME
DRAFTSMAN: _____ SUMMERPLANS

POOL SPECS

PERIMETER: 102 FT RETURNS: 4
AREA: 510 SF SKIMMERS: 2
DIMENSIONS: 30'-0" x 20'-0" AUTOFILL: YES
DEPTH: 3'-6" to 5'-0" BUBBLERS: (2) LED
VOLUME: 16,256 GAL. UMB. SLEEVES: 2
ELEVATION: -12" LIGHTS: (3) 24W COLOR LEDS
DRAINS: 2 SHEERS: (1) 24"
MATERIAL: GUNITE DECK JETS: 3
COPING: IVORY TRAVERTINE 5CM
INTERIOR FINISH: STANDARD WET EDGE SIGNATURE MATRIX
WATERLINE TILE: STANDARD TILE
NOTES:

SPA SPECS

PERIMETER: 28 FT DRAINS: 2
AREA: 49 SF MATERIAL: GUNITE
DIMENSIONS: 7'-0" x 7'-0" JETS: 6
DEPTH: 3'-6" LIGHTS: (1) 6W COLOR LED
VOLUME: 730 GAL. SPILLOVER: 14'-0" TILED
HEIGHT: +12" BLOWER: YES
COPING: IVORY TRAVERTINE 5CM
INTERIOR FINISH: STANDARD WET EDGE SIGNATURE MATRIX
WATERLINE TILE: STANDARD TILE
RAISED FACE: SPLITFACE TRAVERTINE
NOTES:

EQUIPMENT SPECS

CIRCULATION PUMP: JANDY ePUMP 2.7HP VS
ADD'L PUMP(S): JANDY ePUMP 2.7HP VS
FILTER: JANDY CV 460 CARTRIDGE
HEATER: JANDY JXI 400K BTU NG
SANITATION: NATURE2FUSION CHLORINATOR
ADD'L SANITATION: DEL AOP S WALL MOUNT (25K GAL.)
AUTOMATION: iAquaLink IQ904PS
POOL CLEANER: POLARIS ALPHA IQ+
HEAT PUMP / CHILLER: N/A
ACTUATORS: N/A PLUMBING RUN: 45 LF
ELEC. RUN: 10 LF STRAPPED GAS RUN: 10 LF STRAPPED
NOTES:

DECK SPECS

PERIMETER: N/A AREA: 683 SF
SURFACE MATERIAL: SPRAY DECK
COPING AREA / MATERIAL: N/A
RAISED BEAMS (RBB): (6'+12"), (8'+18")
(2) (2'x2') SQUARE PILLARS @ (+18")
RBB FACE/BACK: SPLITFACE TRAVERTINE / BROWNCOAT
NOTES:

ADD'L FEATURES / NOTES

INCLUDES STEP/BENCH/LEDGE TRIM TILE
INCLUDES BAR TOP OVERHANG W/ (4) BAR STOOLS
INCLUDES SUNKEN DECK W/ RETAINING WALLS
INCLUDES (1) GFCI PROTECTED ELECTRICAL OUTLET
INCLUDES (2) FIRE/WATER BOWLS
INCLUDES PLANTER (14'-0" x 2'-0") @ (+18")

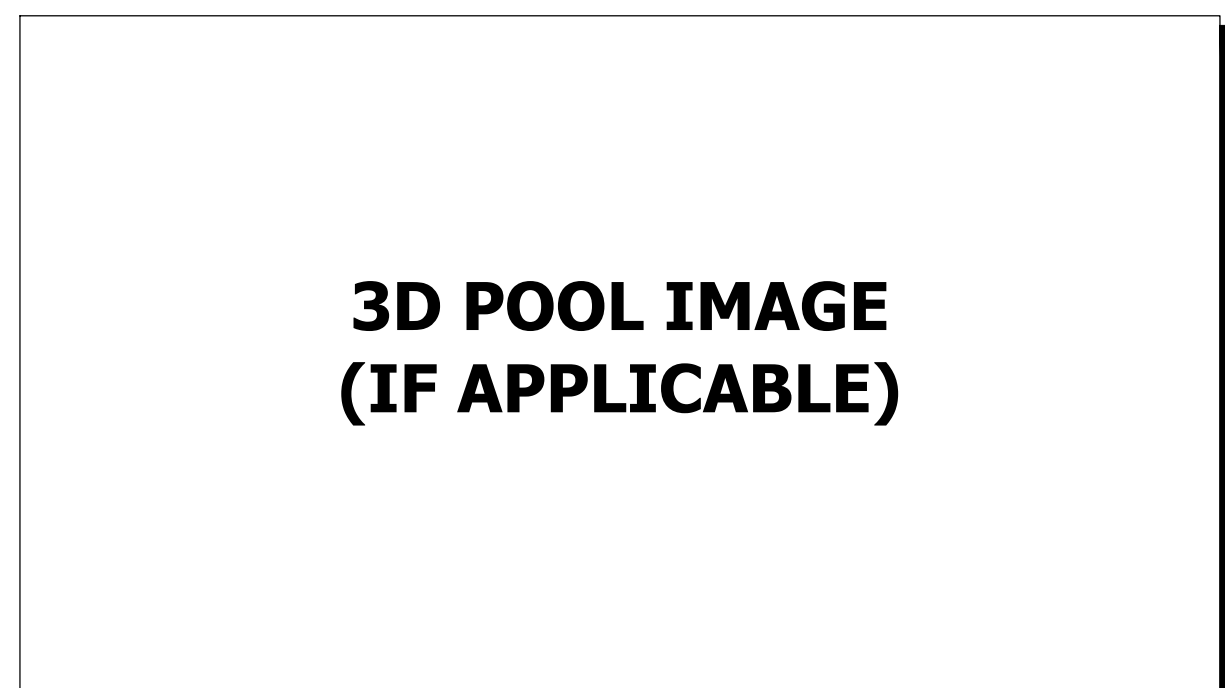
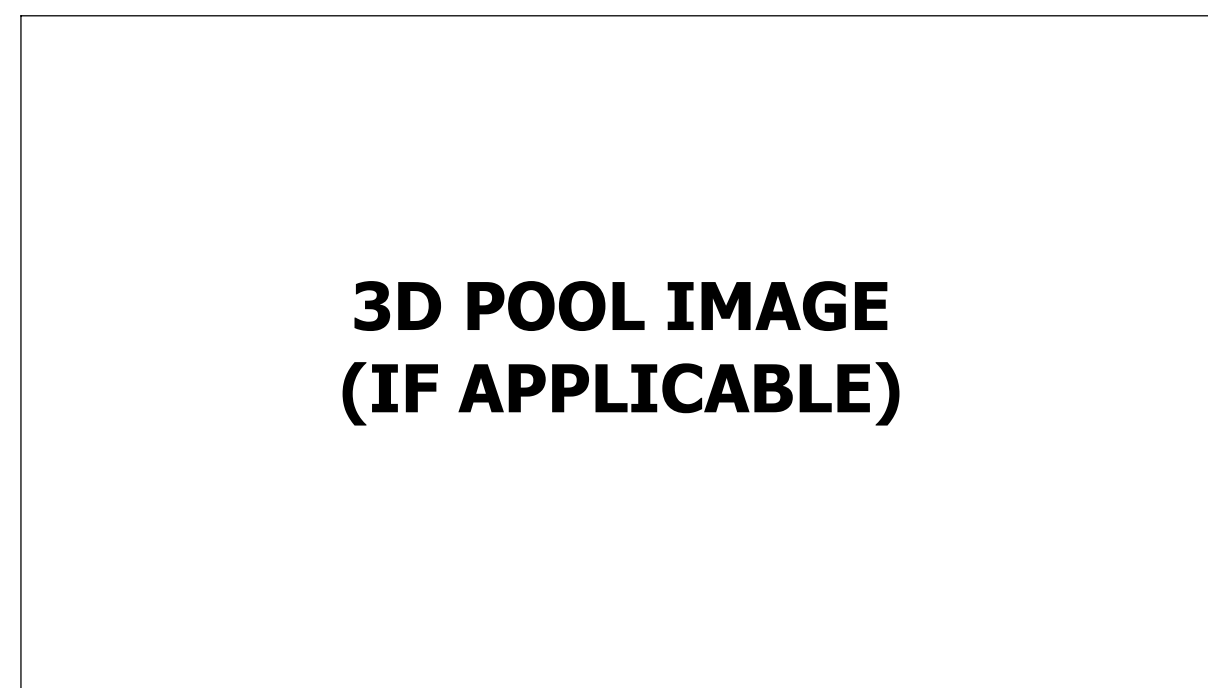
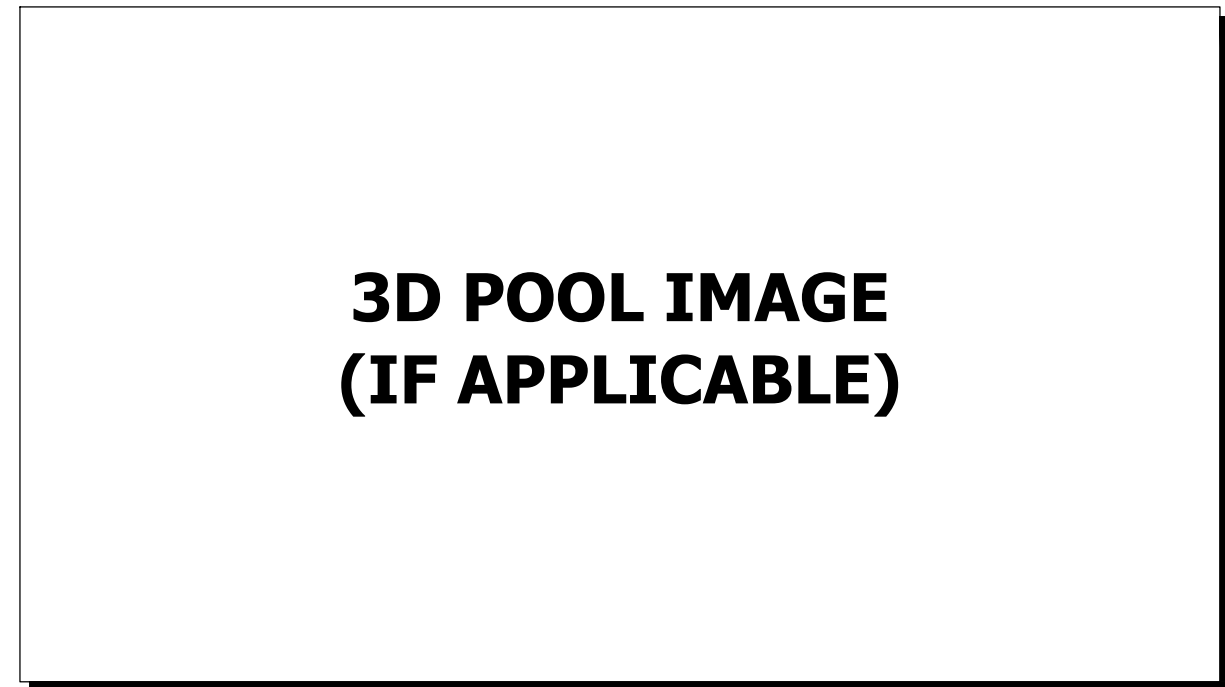
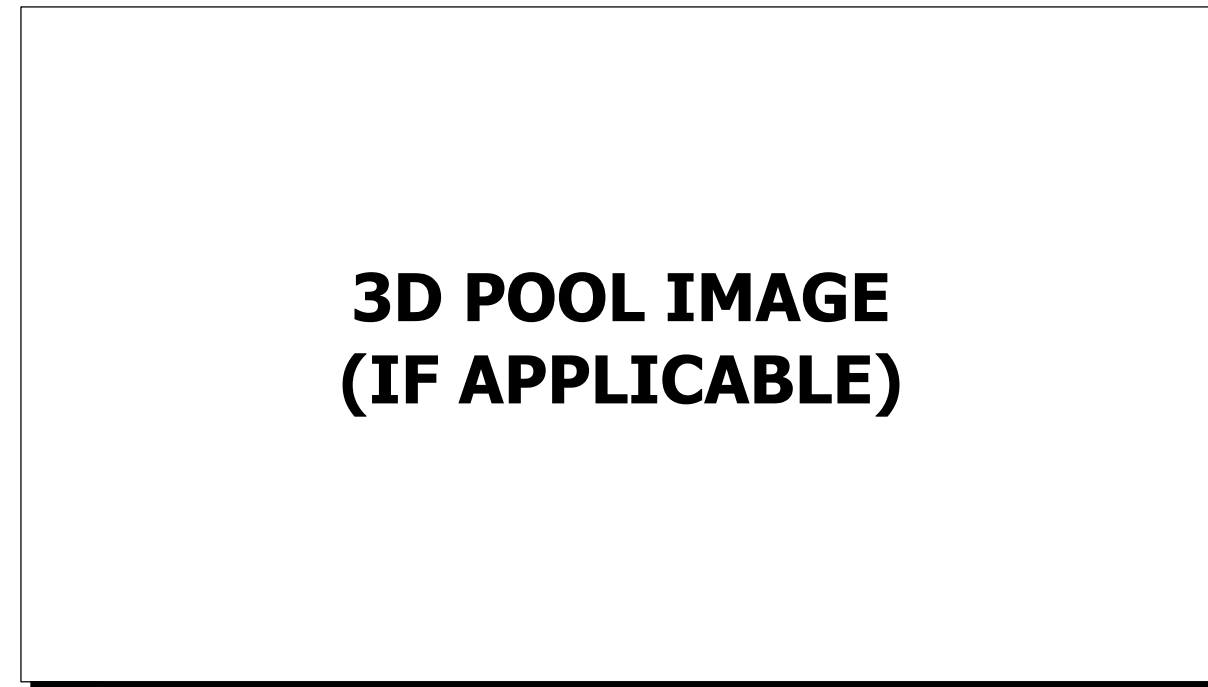

REVISION	DATE
INITIAL PLAN	XX-XX-XX
1	
2	
3	